

INSTRUCTION MANUAL

AQ 102 – Arc Protection Unit

Revision	1.0
Date	October 2011
Changes	Initial version.
Revision	1.1
Date	October 2011
Changes	Product image
Revision	1.2
Date	November 2011
Changes	Chapter 3.3.1 is revised, e.g. a dipswitch forward-and-back feature is added to system configuration. Chapter 3.5.1 is revised, e.g. the scheme selection by dip-switching is added. A selective and non-selective scheme are added in.
Revision	1.3
Date	May 2019
Changes	Add input connection check. Technical data update.

Read these instructions carefully and inspect the equipment to become familiar with it before trying to install, operate, service or maintain it.

Electrical equipment should be installed, operated, serviced, and maintained only by qualified personnel. Local safety regulations should be followed. No responsibility is assumed by Arcteq for any consequences arising out of the use of this material.

We reserve right to changes without further notice.

TABLE OF CONTENTS

1	ABBREVIATIONS.....	5
2	GENERAL.....	6
2.1	Arc protection unit AQ 102 features.....	6
2.2	Simplified block diagram.....	8
3	OPERATION AND CONFIGURATION	9
3.1	LED indicator functions.....	9
3.2	LED Operation Quick Guide	10
3.3	Push-button description.....	11
3.3.1	Auto configuration (system setup).....	11
3.3.2	Reset.....	11
3.3.3	Input connection check.....	12
3.4	Dipswitch settings.....	12
3.4.1	Scheme select dip-switch settings.....	14
3.5	Non-volatile memory.....	16
4	ARC SENSORS.....	17
4.1	Arc light point sensor AQ 01.....	17
4.1.1	AQ 01 Installation and wiring.....	18
4.1.2	AQ 01 Technical data	20
4.2	Arc light fiber optic loop sensor AQ 06	20
4.2.1	AQ 06 Technical data	21
4.3	Arc light fiber optic loop sensor AQ 07	22
4.3.1	AQ 07 Technical data	23
4.4	Arc light fiber optic loop sensor AQ 08	23
4.4.1	AQ 08 Technical data	24
4.5	Sensor Type Dependencies	25
5	SYSTEM SELF-SUPERVISION	26
6	APPLICATION EXAMPLES.....	27
6.1	MV or LV application with current and light condition.....	27
6.2	Circuit breaker failure protection (CBFP).....	28
7	CONNECTIONS.....	29
7.1	Outputs.....	30
7.1.1	Trip relays T1 and T2	30
7.1.2	Trip relays T3 and T4	30
7.1.3	Binary output BO1	30

- 7.1.4 System failure relay SF 31
- 7.2 Inputs..... 31
 - 7.2.1 Arc fiber optic loop sensor channels S1, S2, S3..... 31
 - 7.2.2 Binary inputs BI1 and BI2..... 31
- 7.3 Auxiliary voltage 32
- 8 WIRING DIAGRAM..... 33
- 9 DIMENSIONS AND INSTALLATION 34
- 10 TESTING..... 36
 - 10.1 Carrying out testing in light only mode..... 36
 - 10.2 Carrying out testing in light and current mode 37
 - 10.3 Testing the CBFP function..... 38
 - 10.4 Testing arc flash protection unit operation time 38
 - 10.5 Test plan example..... 39
- 11 TROUBLESHOOTING GUIDE..... 40
- 12 TECHNICAL DATA 41
 - 12.1 Protection..... 41
 - 12.2 Auxiliary voltage 41
 - 12.3 Trip relays T1, T2, T3, T4 41
 - 12.4 System failure relay SF 41
 - 12.5 Binary Output BO1..... 42
 - 12.6 Binary Inputs BI1, BI2..... 42
 - 12.7 Disturbance tests..... 42
 - 12.8 Voltage tests 43
 - 12.9 Mechanical tests 43
 - 12.10 Casing and package 43
 - 12.11 Environmental conditions 43
- 13 ORDERING CODES..... 44
 - 13.1 AQ102 Fiber optic loop sensor unit..... 44
 - 13.2 AQ 0x arc sensors..... 44
- 14 REFERENCE INFORMATION 45



1 ABBREVIATIONS

CB – Circuit breaker

CBFP – Circuit breaker failure protection

EMC – Electromagnetic compatibility

EPROM – Erasable programmable read only memory

HW – Hardware

LED – Light emitting diode

LV – Low voltage

ms – Millisecond

MV – Medium voltage

NC – Normally closed

NO – Normally open

SF – System failure

SW – Software

uP - Microprocessor

2 GENERAL

AQ 102 is a sophisticated micro-processor based arc flash protection unit including complete self-supervision functionality. It is designed to minimize the damage caused by an arcing fault (arc flash) by tripping the circuit breaker sourcing the fault current. The AQ 102 complete system self-supervision function provides the highest level of dependability by continuously monitoring all internal system functions along with external connections.

AQ 102 is designed according to the latest protection relay standards and is hence suitable for installations in rough environments, such as utility, traditional or renewable power plants, offshore, marine, oil and gas, mining, steel or any other heavy industry applications and as well commercial and institutional electrical systems. AQ 102 is suitable for either medium voltage or low voltage switchgear and motor control center applications in both new and retrofit installations.

2.1 ARC PROTECTION UNIT AQ 102 FEATURES

AQ 102 is a multipurpose arc flash protection unit and can be applied for variety of applications. AQ 102 can be used as a stand-alone unit or as part of a more complex arc protection system through the binary bus. Main features of AQ 102:

- 80-265Vac/dc auxiliary power supply or optional 18-72Vdc power supply
- 3 arc fiber loop channels
- 2 binary inputs (nominal voltage of 24 or 110 or 220Vdc)
- 3 normally open trip relay outputs (direct trip circuit rated)
- 1 normally open or optionally normally closed (electronic lock-out) trip relay output (direct trip circuit rated)
- 1 binary output (24Vdc)
- 1 system failure relay output
- 11 Indication LEDs
- Push-button

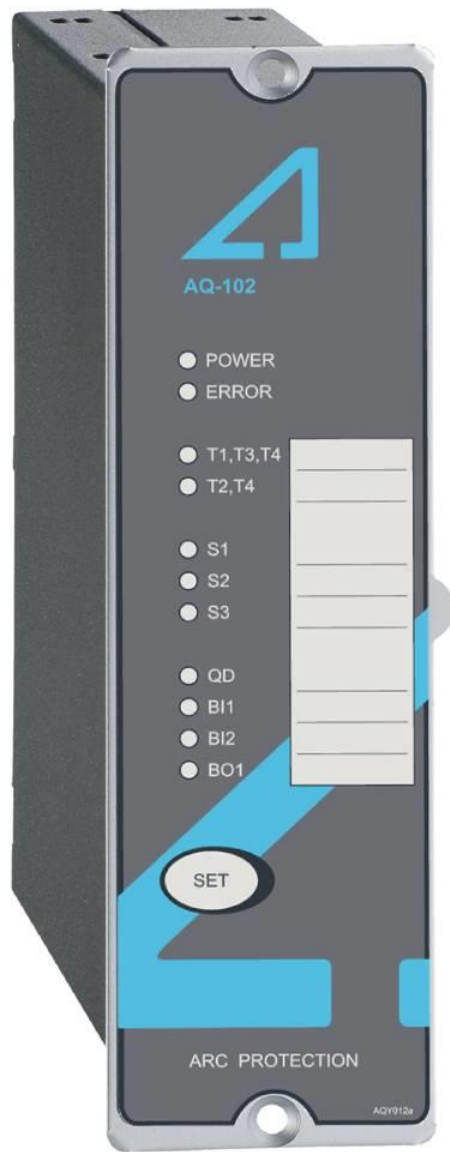

Figure 2-1 Arc protection unit AQ 102

2.2 SIMPLIFIED BLOCK DIAGRAM

AQ 102 simplified block diagram in Figure 2-2 shows the main components of the AQ 102 unit.

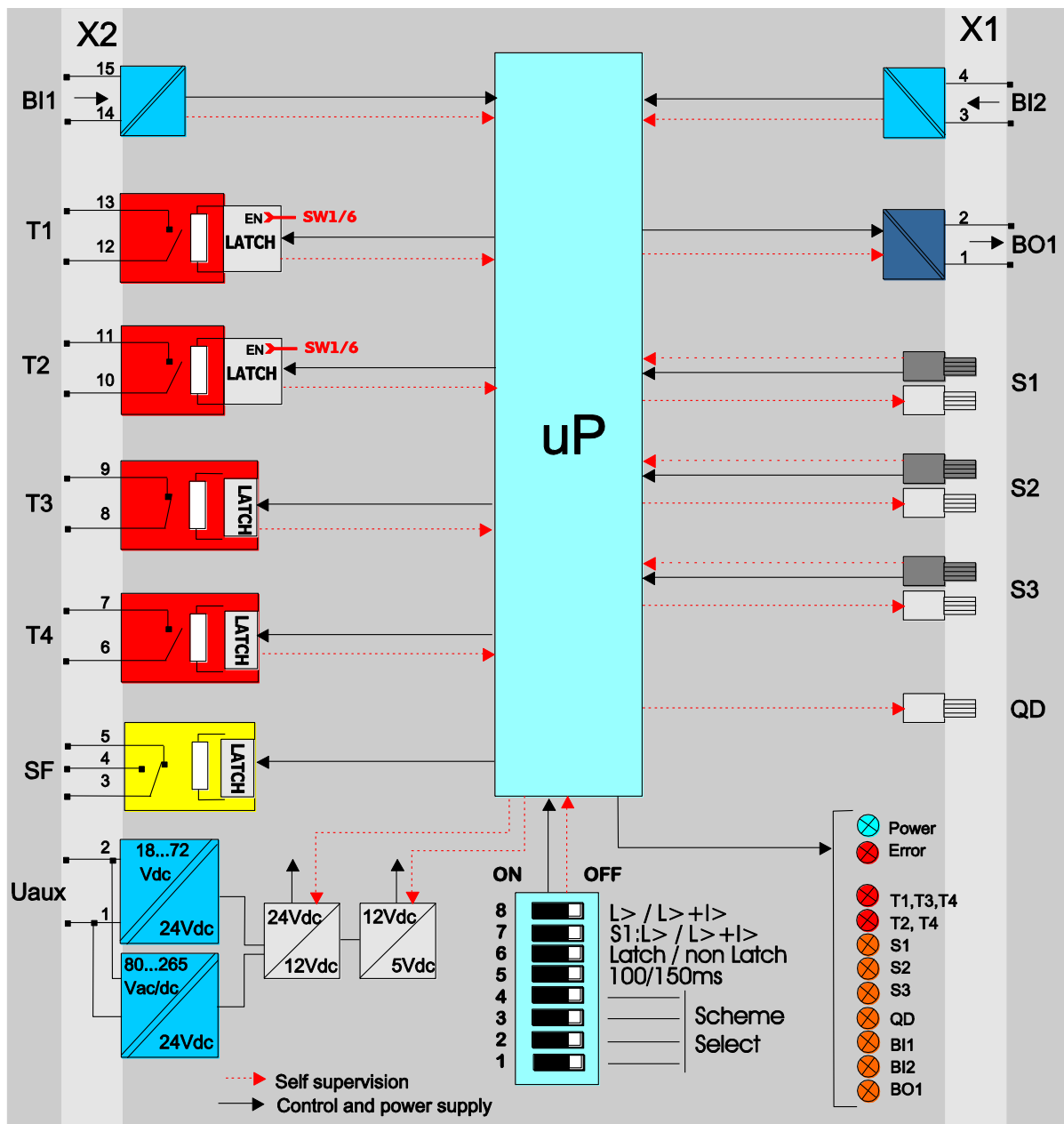

Figure 2-2 AQ 102 simplified block diagram

3 OPERATION AND CONFIGURATION

3.1 LED INDICATOR FUNCTIONS

AQ 102 contains 11 indication LEDs. A user definable text pocket can be slid in for identifying each LED function (except Power and Error LEDs). LED' s are located at the front plate of the unit for clear viewing without a need for opening doors.

During power up the unit performs a LED-test. All LEDs are turned on for 2 seconds and then back off. Only the blue power LED will remain on. When powered up, the unit goes in 50ms into protection mode even while the LED test is being performed.

In normal operation only the blue power LED is ON.

The fiber sensor LEDs in inactive condition are off. If an arc fiber sensor is activated the corresponding sensor channel LED will turn on if the activation is longer than 1.5ms. The sensor LED activation function is latched (steady light). To clear the LED the "SET" button should be pressed.

In case that a fiber sensor connection drops off or configuration mismatch situation is detected by system self-supervision function (new sensor connected without running auto-configuration system setup, see chapter 3.3.1) the corresponding LED will start flashing and the ERROR LED will activate.

AQ102 provides a fiber transmitter channel (QD) for connecting Arcteq arc quenching system type AQ 2000. The QD channel is connected via fiber optic cable to AQ 2000 quenching system for initiating the rapid arc quenching sequence as a result of arc fault detection. For more information refer to AQ 2000 arc quenching system instruction manual.

The Binary I/O LEDs are indicating the I/O-lines status. If any of the lines become active for more than 1.5ms the corresponding LED will turn on (latch).

In trip situation the corresponding trip LED will turn on. Trip outputs are controlled by dipswitch settings. (See chapter 3.4.)

All activation and trip indication LEDs are latched, even if the dipswitch setting is in non-latched mode. They have to be cleared by pushing the "SET" button.

LED indications are stored in non-volatile EPROM memory for identifying the trip information in case the auxiliary power is lost. When re-powering the unit after power supply loss the actual LED status can be visualized from the front of the unit.

3.2 LED OPERATION QUICK GUIDE

LED	OFF	STEADY ON	BLINKING	ACTION IF ABNORMAL
POWER Blue	Auxiliary supply disconnected	Auxiliary power connected	N/A	Check the power source
ERROR Red	System healthy	System failure	Configuration mismatch. Protection partly operational	Verify system condition. see chapters 11: Troubleshooting guide and 5: System self-supervision
T1,T3,T4 Red	Normal status	Trip relays T1,T3,T4 activated	N/A	Check the reason for trip. Clear the fault and reset indications by pushing SET button
T2, T4 Red	Normal status	Trip relays T2, T4 activated	N/A	Check the reason for trip. Clear the fault and reset indications by pushing SET button
S1 Amber	Normal status	Fiber sensor channel activated	Fiber sensor drops off or system set-up not performed	Check why sensor activated or check the sensor continuity or perform system set-up (see chapter:3.3.1 Auto configuration (system setup))
S2 Amber	Normal status	Fiber sensor channel activated	Fiber sensor drops off or system set-up not performed	Check why sensor activated or check the sensor continuity or perform system set-up (see chapter:3.3.1 Auto configuration (system setup))
S3 Amber	Normal status	Fiber sensor channel activated	Fiber sensor drops off or system set-up not performed	Check why sensor activated or check the sensor continuity or perform system set-up (see chapter:3.3.1 Auto configuration (system setup))
QD Amber	Normal status	Quenching Device channel activated	Fiber connection to quenching system drops off or system set-up not performed	Check the fiber connection and/or the system configuration.
BI1 Amber	Normal status	Binary input 1 activated	Binary input 1 loose connection	Check the binary input wiring.
BI2 Amber	Normal status	Binary input 2 activated	Binary input 2 loose connection	Check the binary input wiring.
BO1 Amber	Normal status	Binary Output activated	N/A	

Table 3-1: LED operation quick guide

3.3 PUSH-BUTTON DESCRIPTION

AQ 102 contains one single push-button (SET) that can be used for all operational functions of the unit. The push-button is utilized for auto-configuration of the system (see chapter 3.3.1) and for resetting the indicators and latched output relays.

3.3.1 AUTO CONFIGURATION (SYSTEM SETUP)

When all sensors and binary lines have been connected an auto-configuration procedure must be executed. The initialization sequence is performed by pressing the "SET" -button for 2 seconds, and the AQ 102 sensor LEDs and BI1/BI2 LEDs start blinking. The unit scans these inputs to see if they are connected and when input is detected the corresponding LEDs are lit up to mark that a connection was found. The inputs without connection continue blinking during the remaining 3 seconds. After total time of 5 seconds, all LEDs are turned off. During this system setup the dipswitch settings are also stored in non-volatile memory.

All sensor inputs will remain operational even when not auto-configured. The auto-configuration is only used for self-supervision purposes.

Note: in order to redo auto-configuration for a unit containing less connections (binary inputs/outputs or sensors) than in previous memorized set-up a dipswitch (anyone) must be moved back and forth prior to performing auto-configuration. Timeout allowing new configuration is 1 minute. Reconfiguration with more connections is allowed without moving the dipswitch.

3.3.2 RESET

All LED indications and latched trip relays are reset by pressing the "SET" button for 1 second. Otherwise the latched trip relays will remain activated until auxiliary power is disconnected. All LED indications will remain active until reset is performed by the operator even when auxiliary power supply is disconnected (see chapter 3.5 Non-volatile memory).

3.3.3 INPUT CONNECTION CHECK

After the auto-configuration procedure is completed, the connectivity of all sensors and binary input channels can be verified by pressing the push-button 3 times (in 2 seconds). The LED of corresponding sensors and binary input channels starts to blink while the POWER LED is blinking. The number of LED blinks are exact same as the number of connected sensors and connected binary output channels from other units.

3.4 DIPSWITCH SETTINGS

AQ 102 functionality such as tripping logic is configured using dipswitch settings. Different trip schemes can be easily programmed by selecting the appropriate dipswitch positions. This gives users the flexibility to change settings dependent on the demand of application. Tripping may be selected based on arc light only or arc light and current thresholds (or other tripping criterion such as undervoltage, or similar). Current thresholds or other tripping criterion may be applied to binary input BI1 for blocking trip caused by natural light sources. Also the CBFP time can be selected by dipswitch setting according to the requirement of the CBFP function. Dipswitches are located at the back of the unit for easy access. See Figure 3-1 AQ 102 dipswitches and Table 3-2 AQ102 dipswitch setting for details of settings.

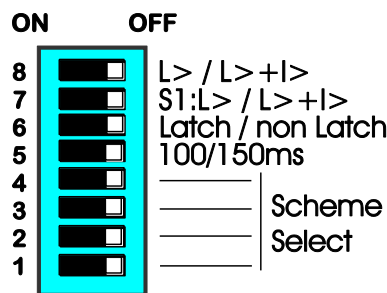

Figure 3-1 AQ 102 dipswitches

Dipswitch	Function selection	ON (LEFT POSITION)	OFF (RIGHT POSITION)
8 L> / L>+I>	Fiber sensor channels S2 and S3 trip criteria	Trip on light only (L>).	Trip on light and overcurrent (L> + I>). Both signals are required simultaneously to trip.
7 S1: L> / L>+I>	Sensor channel S1 trip criteria	Trip on light only (L>).	Trip on light and overcurrent (L> + I>). Both signals are required simultaneously to trip.
6 Latch / non-latch	Latch or non-latch for trip relays T1 and T2	T1 and T2 operate as non-latched. Note: Trip relays T3 and T4 are always latched. Binary output BO1 function is always non-latched.	T1 and T2 operate as non-latched.
5 100 / 150ms	CBFP time setting	CBFP time is set to 100ms.	CBFP time is set to 150ms.
4 Scheme select	Scheme selection	Refer to chapter 3.4.1 and 6	Refer to chapter 3.4.1 and 6
3 Scheme select	Scheme selection	Refer to chapter 3.4.1 and 6	Refer to chapter 3.4.1 and 6
2 Scheme select	Scheme selection	Refer to chapter 3.4.1 and 6	Refer to chapter 3.4.1 and 6
1 Scheme select	Scheme selection	Refer to chapter 3.4.1 and 6	Refer to chapter 3.4.1 and 6

Table 3-2 AQ102 dipswitch setting selection

The chapter 3.4.1 shows AQ102 internal logic and dipswitch selections. For inputs and outputs descriptions refer to chapter 7.

3.4.1 SCHEME SELECT

This chapter describes the available schemes that are configured using the Scheme Select 1...4 dip-switches.

- **Logic scheme 0**

The AQ102 logic scheme 0 can be not only applied as stand-alone arc protection unit, but also widely used as non-selective outgoing feeder compartment protection. Depend on this scheme, user can either select light only mode or arc light + overcurrent mode to trip all circuit breakers. The detailed instruction is described in AQ SAS™ booklet.

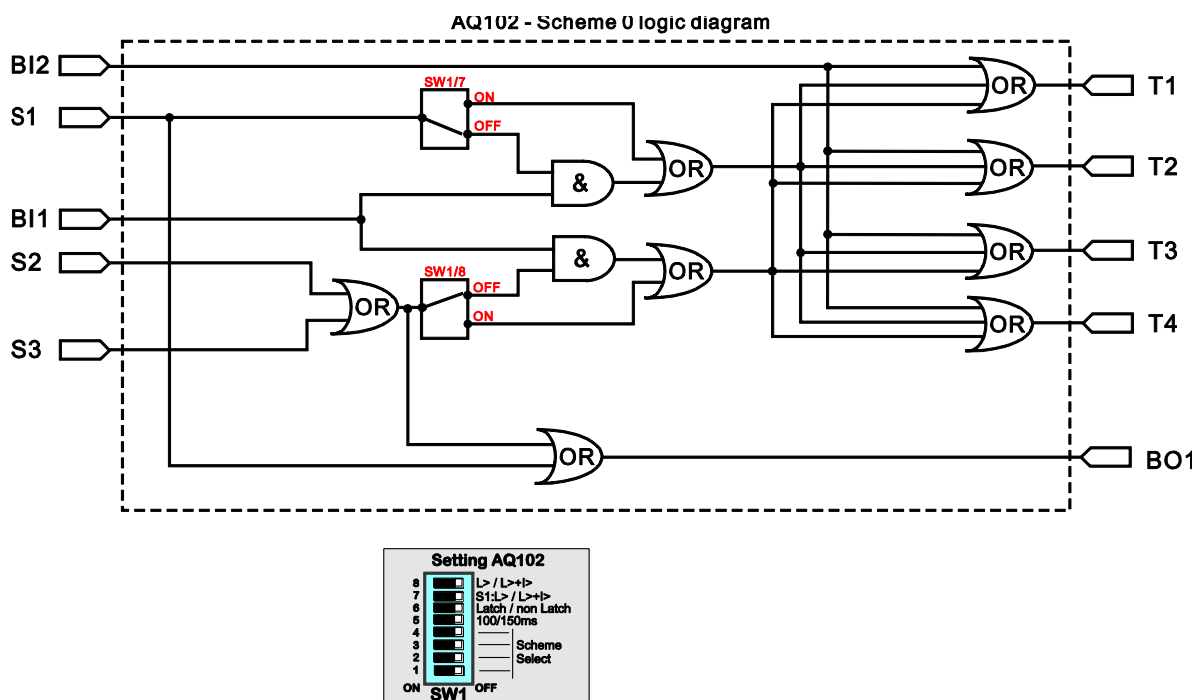

Figure 3-2: AQ102 logic scheme 0

- **Logic scheme I**

The AQ102 logic scheme I is mainly utilized in selective arc protection solution. The fiber sensor S1 monitors the outgoing feeder cable compartment. The fiber sensor S2 monitors the corresponding feeder breaker compartment and busbar compartment. Trip contact T1 is responsible for tripping circuit breaker of the outgoing feeder. The detailed instruction is described in AQ SAS™ booklet.

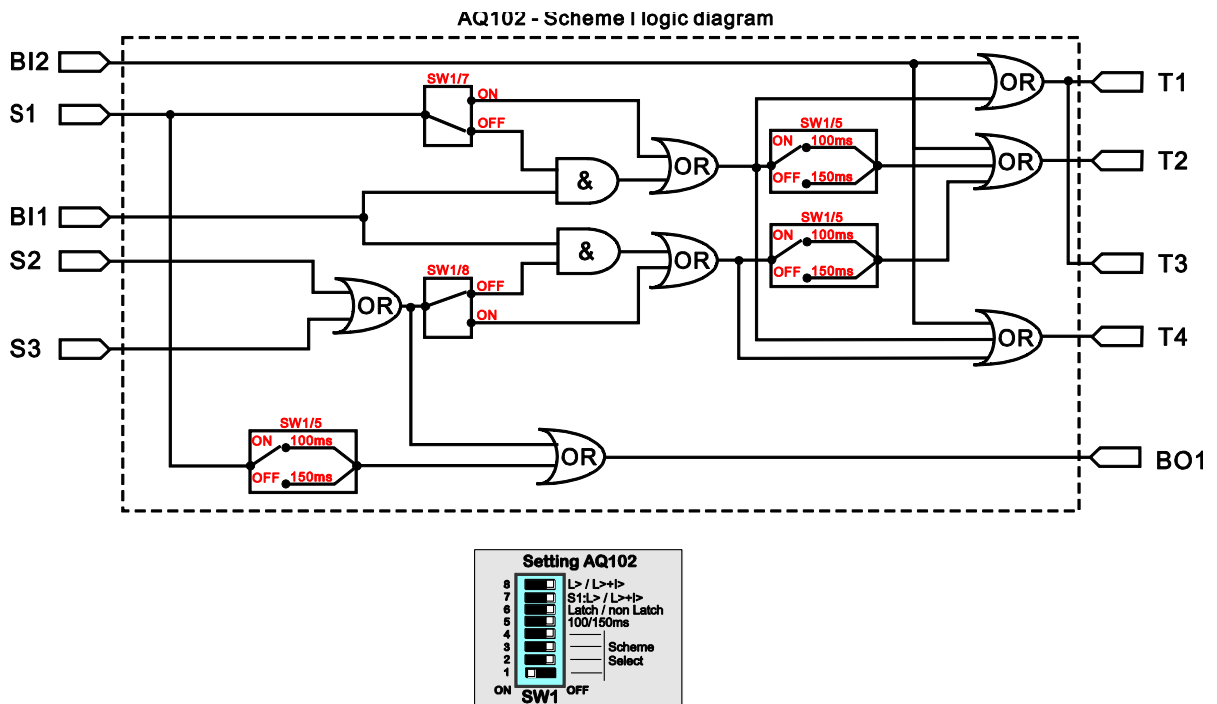

Figure 3-3: AQ102 logic scheme I

3.5 NON-VOLATILE MEMORY

All critical system data including dipswitch settings and auto-configuration file described in chapter 3.3.1 are stored in EPROM non-volatile memory to ensure correct operation and full self-supervision even if auxiliary power is lost temporarily.

Also, all LED indications described in chapter 3.1 are stored in non-volatile memory in order to provide quick recovery of the system status indication even if auxiliary power is lost temporarily. This feature is especially important if auxiliary power is lost after tripping.

Non-volatile memory does not require a power supply to maintain information and will retain settings and indications permanently without power.

4 ARC SENSORS

AQ 100 series provides choice of different types of arc sensors to be utilized in different units and different switchgear types according to specific application requirements. Available sensor types are arc light point sensors and arc light fiber optic loop sensors.

Arc light point sensors are typically installed in metal clad compartments providing quick accurate location of the faulted area. Arc light fiber loop sensors are installed typically to cover a wider protected area with one fiber when no need for more exact fault location exists.

4.1 ARC LIGHT POINT SENSOR AQ 01

AQ 01 is an arc light point sensor with a light sensitive photodiode element activated by arc light. AQ01 arc sensors should be mounted in the switchgear cubicles in such a way that the light sensitive part covers the protected area as completely as possible. One sensor per closed metal clad compartment should be utilized. In open spaces, such as the bus bar section, arc sensors should be mounted maximum 2 meters apart.

The fixed light sensitivity of the AQ01 sensor is 8000 Lux. Sensor does not require user settings. Detection radius is 180 degrees.

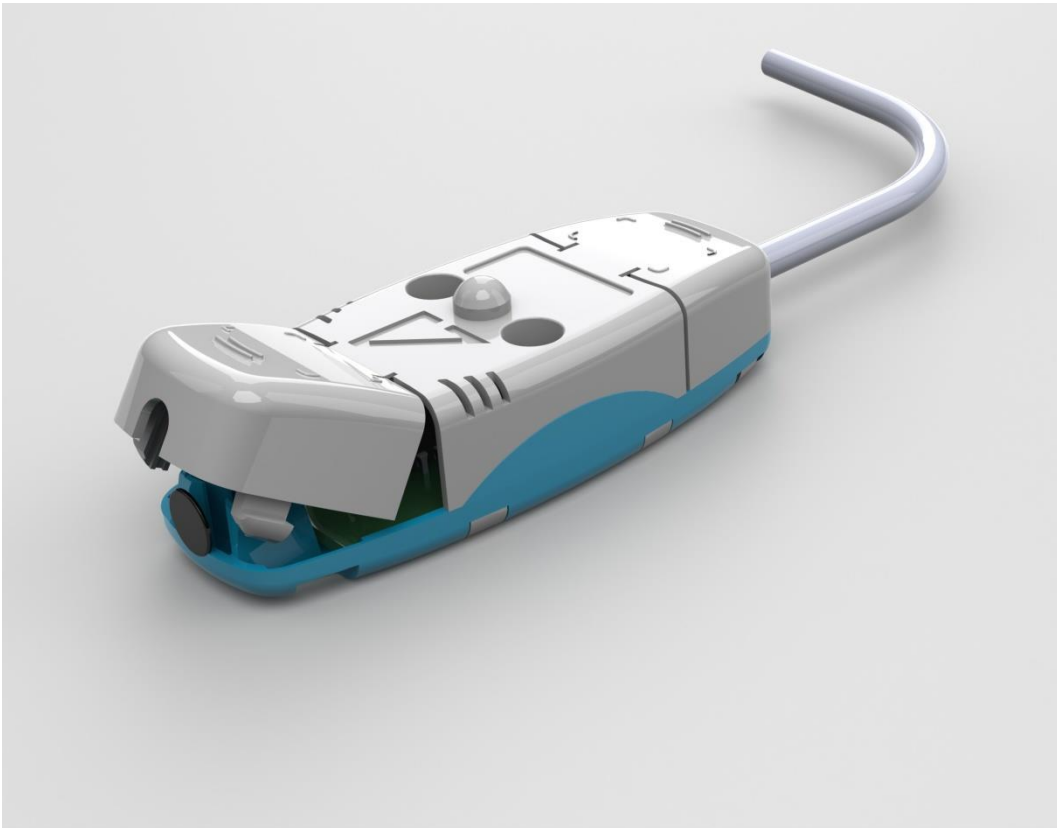

Figure 4-1: Arc sensor AQ 01

4.1.1 AQ 01 INSTALLATION AND WIRING

AQ 01 is installed either on the compartment wall or through wall. Example of wall mounting is seen in Figure 4-2. AQ 01 is fixed to the wall using two screws. The same screw pattern is utilized in through wall mounting arrangement as well. Unit is turned around and the eye is pushed to the compartment to be protected and two screws are attached from the back side of the sensor. No external mounting plates are needed in any case.



Figure 4-2: AQ 01 mounted to compartment wall.

AQ01 comes without connection cable. Connection cable installation at site is simple. Cable connectors are located beneath the covers that can be conveniently detached for fastening the sensor wires. Cover shall be attached after installing the wires. Cable connectors are located at both ends of the sensor for series connecting maximum three sensors in one line. See Figure 4-1.

4.1.2 AQ 01 TECHNICAL DATA

Light intensity threshold	8000Lux
Detection radius	180 degrees
Mechanical protection	IP 64
Sensor wiring arrangement	2 wires and shield
Sensor cable specification	Shielded twisted pair 0.75mm ²
Maximum sensor cable length per sensor channel	100 meters
Operating temperature	-20...+85 °C

4.2 ARC LIGHT FIBER OPTIC LOOP SENSOR AQ 06

AQ 06 is an arc light fiber optic loop sensor. AQ 06 fiber is a plastic fiber optic cable. AQ 06 sensors can be ordered in pre-manufactured lengths of 1-40 meters. AQ 06 fiber sensors are distributed through the protected switchgear cells. AQ 06 is not recommended to be cut and/or spliced on site. If cutting/splicing is necessary due to accidental breakage, please contact your nearest Arcteq representative.

The fixed light sensitivity of the AQ06 sensor is 8000 LUX. Sensor does not require user settings. Detection radius is 360 degrees. See figure 4.3

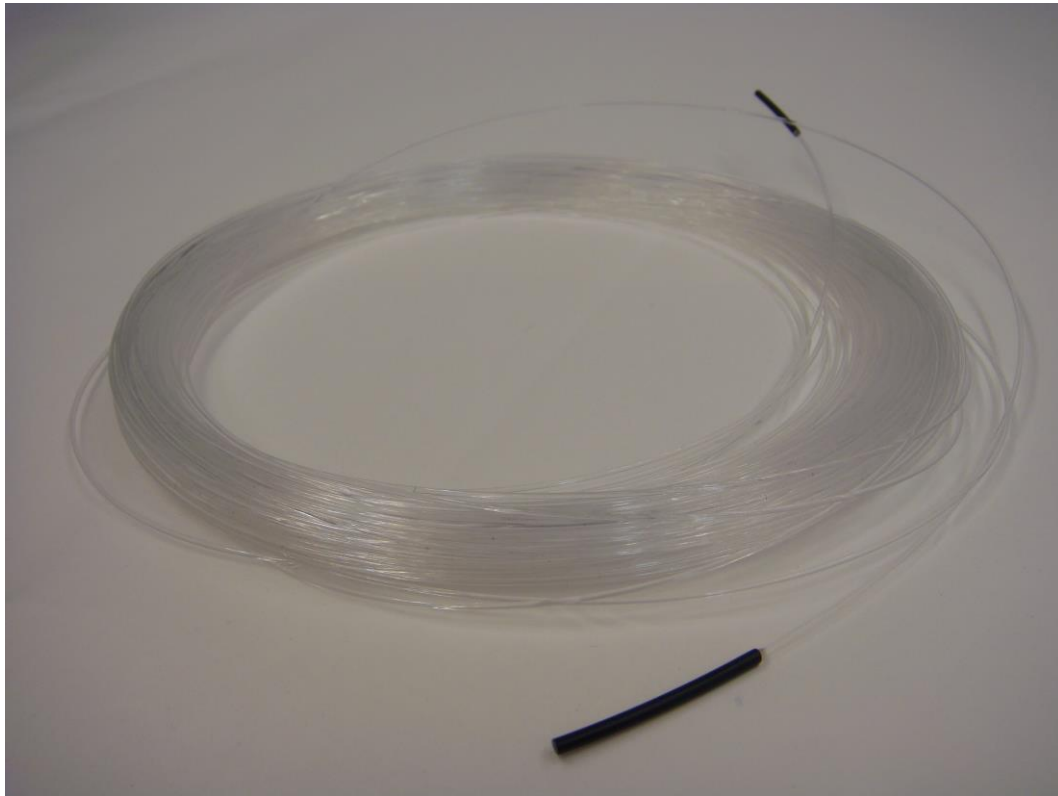

Figure 4.3 AQ06 arc light fiber optic loop sensor

Note: On request AQ 06 ends can be covered with black rubber part for any requested portion to avoid light detection outside the protected zone. For more information consult your nearest Arcteq representative.

4.2.1 AQ 06 TECHNICAL DATA

Light intensity threshold	8000Lux
Detection radius	360 degrees
Maximum length	40 meters
Diameter	1 millimeter
Bending radius	5 centimeters
Operating temperature	-10...+85 °C

4.3 ARC LIGHT FIBER OPTIC LOOP SENSOR AQ 07

AQ 07 is an arc light fiber optic loop sensor. AQ 07 fiber is a robust fiber optic cable providing practically unlimited bending radius. AQ 07 contains hundreds of glass fiber drains covered by a plastic tube making it extremely strong. AQ 07 sensors can be ordered in pre-manufactured lengths of 1-50 meters. AQ 07 fiber sensors are distributed through the protected switchgear cells. AQ 07 is not recommended to be cut and/or spliced on site. If cutting/splicing is necessary due to accidental breakage, please contact your nearest Arcteq representative.

The fixed light sensitivity of the AQ07 sensor is 8000 LUX. Sensor does not require user settings. Detection radius is 360 degrees. See figure 4.4



Figure 4.4 AQ07 arc light fiber optic loop sensor

Note: On request AQ 07 ends can be covered with black rubber part for any requested portion to avoid light detection outside the protected zone. For more information consult your nearest Arcteq representative.

4.3.1 AQ 07 TECHNICAL DATA

Light intensity threshold	8000Lux
Detection radius	360 degrees
Maximum length	50 meters
Diameter	1.2 millimeters
Bending radius	1 centimeter
Operating temperature	-40...+85 °C

4.4 ARC LIGHT FIBER OPTIC LOOP SENSOR AQ 08

AQ 08 is an arc light fiber optic loop sensor. It is developed to withstand temperatures of up to 125 degrees Celsius and is therefore suitable for installation in e.g. wind turbine windings. AQ 08 fiber is a robust fiber optic cable providing practically unlimited bending radius. AQ 08 contains hundreds of glass fiber drains covered by a plastic tube making it extremely strong. AQ 08 sensors can be ordered in pre-manufactured lengths of 1-40 meters. AQ 08 fiber sensors are distributed through the protected switchgear cells. AQ 08 is not recommended to be cut and/or spliced on site. If cutting/splicing is necessary due to accidental breakage please contact your nearest Arcteq representative.

The fixed light sensitivity of the AQ08 sensor is 8000 LUX. Sensor does not require user settings. Detection radius is 360 degrees. See figure 4.5.

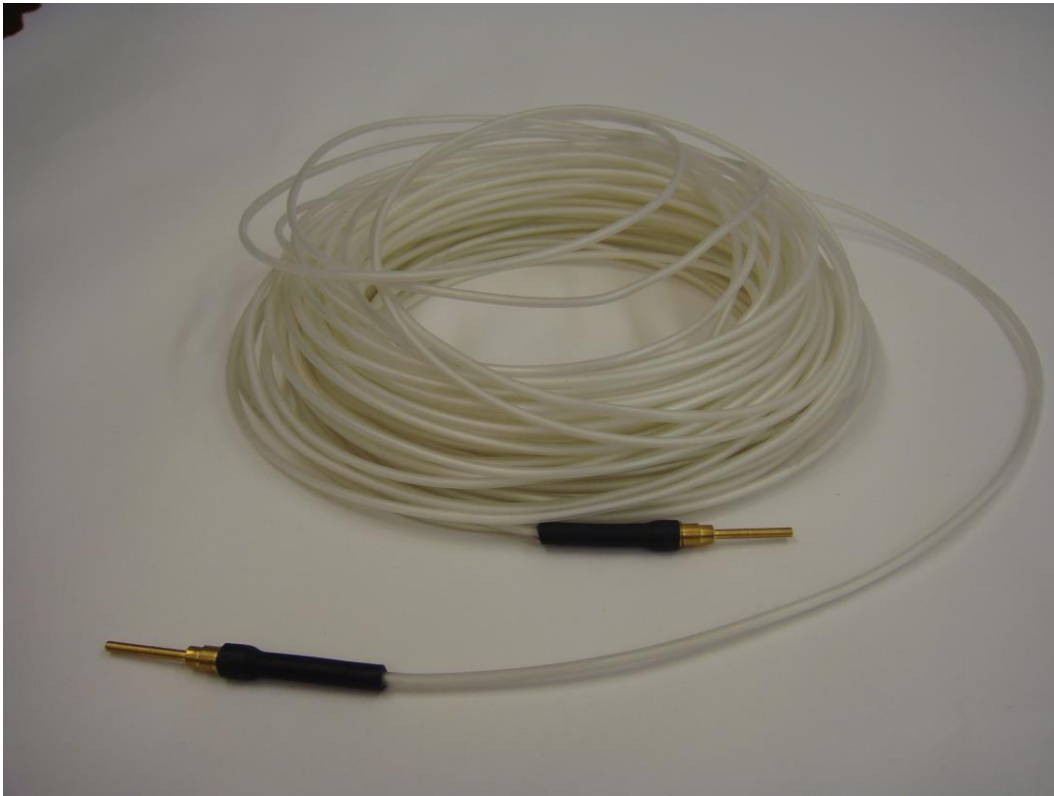

Figure 4.5 AQ08 arc light fiber optic loop sensor

Note: On request AQ 08 ends can be covered with black rubber part for any requested portion to avoid light detection outside the protected zone. For more information consult your nearest Arcteq representative.

4.4.1 AQ 08 TECHNICAL DATA

Light intensity threshold	8000Lux
Detection radius	360 degrees
Maximum length	40 meters
Diameter	1.2 millimeters
Bending radius	1 centimeter
Operating temperature	-40...+125 °C

4.5 SENSOR TYPE DEPENDENCIES

Different sensor types can be utilized in different arc flash protection units of the AQ 100 series. The table below describes the dependencies.

Table 4-1: Arc sensor dependencies

	AQ 01	AQ06	AQ07	AQ08
AQ101	Yes	Yes (with fiber option)	Yes (with fiber option)	Yes (with fiber option)
AQ102	No	Yes	Yes	Yes
AQ110P	Yes	Yes (with fiber option)	Yes (with fiber option)	Yes (with fiber option)
AQ110F	No	Yes	Yes	Yes

5 SYSTEM SELF-SUPERVISION

AQ102 includes an extensive self-supervision feature. Self-supervision includes both internal functions and external connections. The self-supervision module monitors power supply, HW and SW malfunctions and binary input connection and sensor problems. Dipswitch settings are also supervised by comparing actual value with stored Non-volatile memory data (see chapter 3.3.1 Auto configuration (system setup))

In a healthy condition the power LED is on and the System Failure (SF) relay is energized. If the self-supervision function detects a faulty condition or the power supply fails the self-supervision relay is released and the ERROR LED is lit.

If a fiber sensor failure occurs, the unit will go into ERROR mode. The error LED will turn on, the SF relay will release and the corresponding faulty fiber sensor channel LED will start blinking. In this situation the unit is still in protection mode, but with the faulty fiber sensor channel blocked. If the error is resolved the unit will automatically clear the SF-status. This means that SF relay will energize and the error led will turn off. If one or more of the sensors are disconnected the healthy sensors remain in use and unit remains operational accordingly. The AQ102 will remain in error mode until the disconnected sensors are repaired.

If a dip switch setting is changed after the auto-configuration function (see chapter 3.3.1 Auto configuration) has been executed, the unit will go into SF-alarm mode. The configured (stored) setting is however still valid and the unit is still operational.

6 APPLICATION EXAMPLES

AQ102 may be applied to a variety of power switchgear and controlgear layouts and technologies. Some typical applications are described in this section. Please consult your nearest Arcteq representative for a solution to your particular application.

6.1 MV OR LV APPLICATION WITH CURRENT AND LIGHT CONDITION

AQ102 may be applied requiring both overcurrent and arc light conditions for trip. In this case tripping is performed only if both conditions are fulfilled simultaneously. Typically the overcurrent condition is obtained from the AQ 110 unit and the trip relay will be activated in 7ms. The overcurrent condition may be monitored by non-Arcteq products also (e.g. generic feeder protection relay) and the total operation time is then dependent on device feeding the overcurrent signal to AQ102.

The sensor channel S1 can be set to operate on light only even if other channels operate on both conditions of arc light and overcurrent.

Figure 6-1 shows an example of a system applying both overcurrent and arc light for tripping from the fiber sensor channels S2 and S3 activations and arc light only from fiber sensor channel S1 activation. S1 channel is monitoring the transformer feeder bus duct above the current monitoring point. S2 channel is monitoring the main breaker and the busbar. S3 channel is monitoring each feeder. For the maximum length of each fiber sensor type refers to chapter 4 Arc Sensors.

The current monitoring signal is in this application coming from an external overcurrent relay.

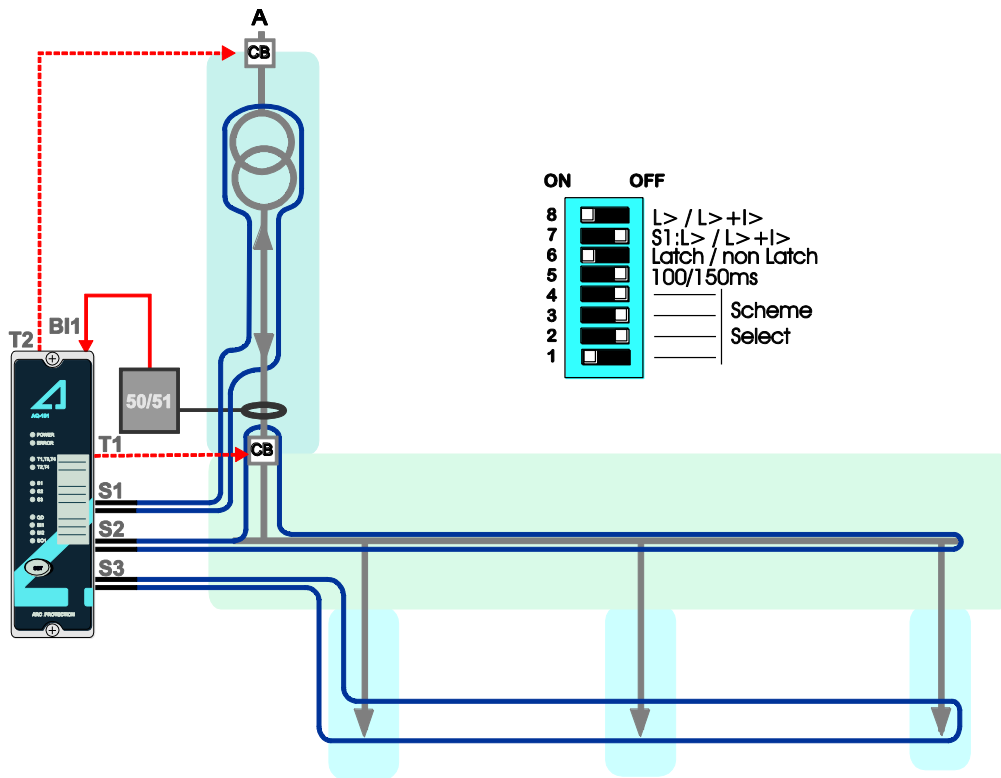

Figure 6-1: LV or MV stand-alone application.

Figure 6-1: LV or MV application example with light and current tripping criteria for fiber sensor channels S2 and S3. The sensor channel S1 monitoring the zone before CT is set to operate on light only. The current threshold monitoring signal may come either from an external overcurrent relay or from AQ 110 arc protection unit. In this example an overcurrent relay (50/51) is applied to monitor the overcurrent condition.

6.2 CIRCUIT BREAKER FAILURE PROTECTION (CBFP)

AQ102 includes a selective circuit breaker failure function which can be enabled by dipswitch setting (see chapter 3.4 Dipswitch settings). When enabled, the breaker failure function activates when the tripped breaker fails to operate. Breaker failure function is activated if AQ102 detects the presence of light after a set operate time. When AQ102 is set to operate on light and current both parameters must persist to activate CBFP. Breaker failure can be set to operate either on 100ms or 150ms delay (see chapter 3.4 Dipswitch settings).

7 CONNECTIONS

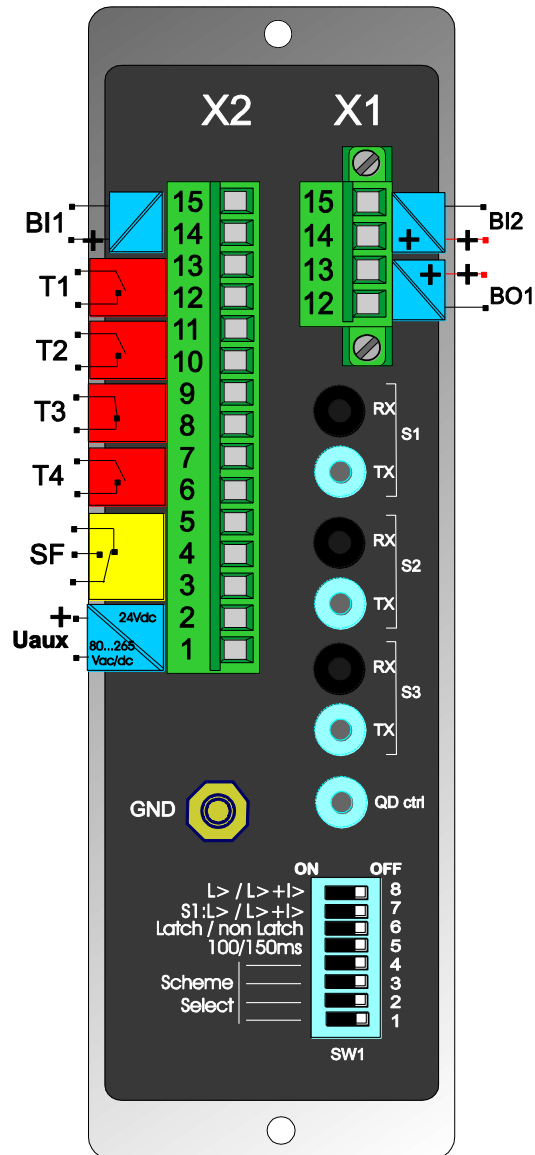

AQ102 connections.cdr

Figure 7-1: AQ102 terminals at rear plate

7.1 OUTPUTS

7.1.1 TRIP RELAYS T1 AND T2

The AQ102 unit has integrated trip relays T1 and T2 for tripping of the circuit-breakers. T1 and T2 relays are normally open type (NO).

7.1.2 TRIP RELAYS T3 AND T4

T3 relay output may act either as an electronic lock-out relay or as a trip relay. This option must be specified when ordering. When T3 is factory configured as electronic lock-out relay it is normally closed type (NC) and will hold its position until manual reset command or until auxiliary power supply is lost. When re-applying the auxiliary power supply the electronic lock-out relay will return to the contact condition prior losing the auxiliary power. This normally closed relay output can be used for tripping contactor controlled devices.

Alternately T3 can be ordered as normally open (NO) type relay from the factory.

T3 relay follows the operation of T1 and activates whenever T1 is activated.

Trip relay T4 is a common trip relay that operates anytime T1 or T2 relay operates and can be used either for tripping one more disconnecting device or for trip alarm to local or remote monitoring and alarming system.

7.1.3 BINARY OUTPUT BO1

One binary output is available (+24V dc). Binary output function can be configured using dipswitches (see chapter 3.4 Dipswitch settings).

Note: the binary output is polarity sensitive (see chapter 8 Wiring diagram).

7.1.4 SYSTEM FAILURE RELAY SF

System failure relay SF is a changeover type (NO/NC) and is energized in healthy condition. Whenever AQ102 detects a system error or disconnection of the auxiliary power supply the contact changes its state. The state of the SF relay remains the same until the unit returns to a healthy condition and SF relay is energized again.

7.2 INPUTS

7.2.1 ARC FIBER OPTIC LOOP SENSOR CHANNELS S1, S2, S3

AQ102 has 3 fiber optic loop sensor channels with transceivers and receivers (Tx, Rx). When the fiber optic loop sensor is connected to the unit one end is connected to Tx and another to Rx. This sensor loop is then continuously monitored by means of test light pulse travelling through the loop. In case of discontinuity in the loop the unit goes into error mode and activates the error LED and SF relay output.

Maximum 40 centimeter length of fiber sensor (type AQ 06 and type AQ08) and maximum 50 centimeter length of fiber sensor (type AQ07) can be connected to each channel.

For details on sensors refer to chapter 4 Arc Sensors.

7.2.2 BINARY INPUTS BI1 AND BI2

AQ102 contains two binary inputs. The BI1 is always reserved for second trip criteria signal. In the most typical application AQ102 is receiving overcurrent information from Arcteq AQ 110 device. Overcurrent information may come also from non-Arcteq device (e.g. upstream protection relay). Alternately any other signal (such as undervoltage, or similar) can be used as second trip criteria along with light information.

Note: when AQ102 receives overcurrent signal from a non-Arcteq device the actual operation time depends on the operation time of the external device and so total operational time cannot be specified or guaranteed.

The BI2 can be used for receiving a trip signal or arc light signal. The function of the BI2 is configured using dipswitches, see chapter 3.4 Dipswitch settings.

The inputs are activated by connecting a dc signal exceeding the specified nominal threshold level of the corresponding input. There are three different nominal threshold levels available, 24 or 110 or 220 Vdc. The desired threshold value has to be specified when ordering. The actual activation of the binary input occurs at 80% of the specified nominal threshold value (i.e. 19 Vdc, 88 Vdc or 176 Vdc).

7.3 AUXILIARY VOLTAGE

The auxiliary power supply voltage is 80...265Vac/dc. Optionally an 18...72Vdc version is available.

After powering up the unit protection is active and operational within 50ms.

8 WIRING DIAGRAM

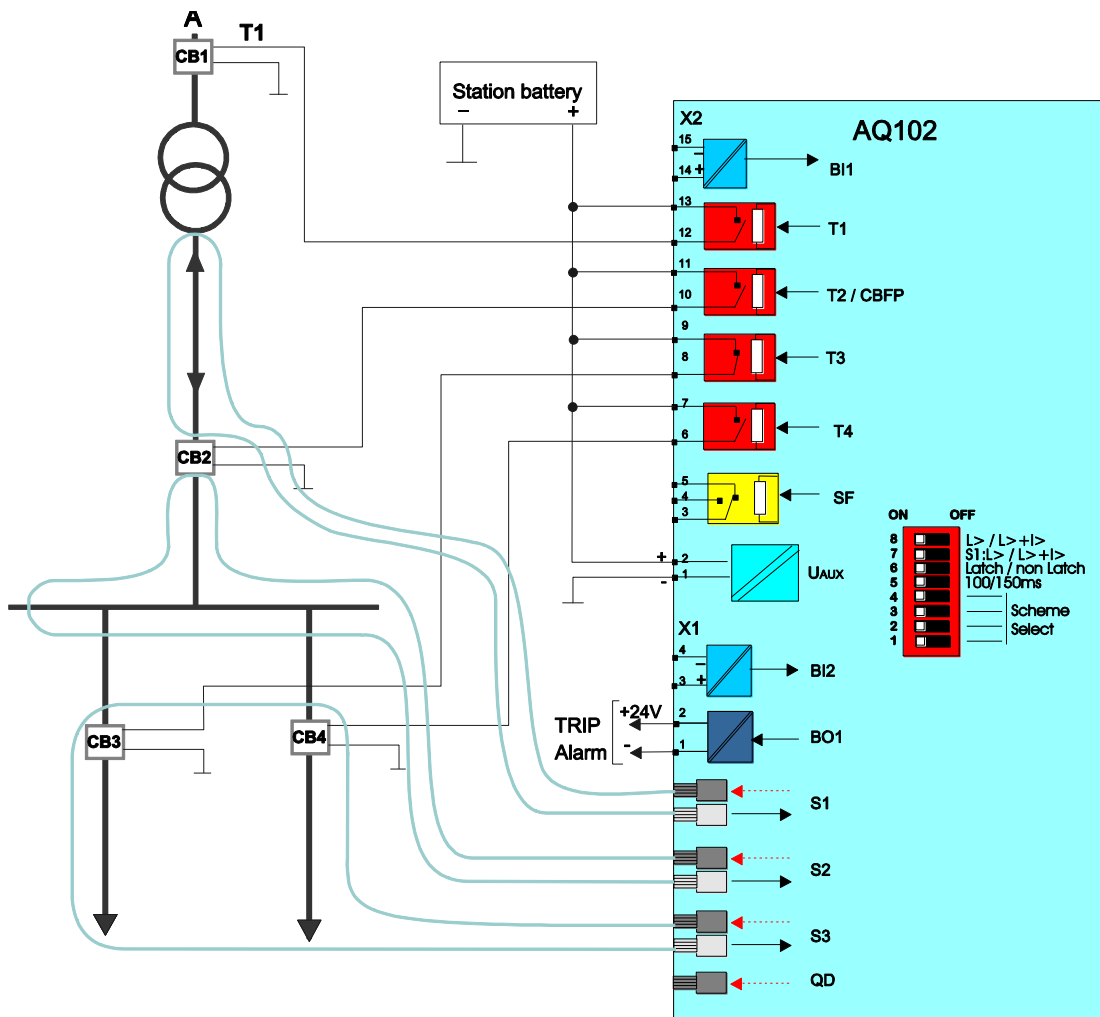
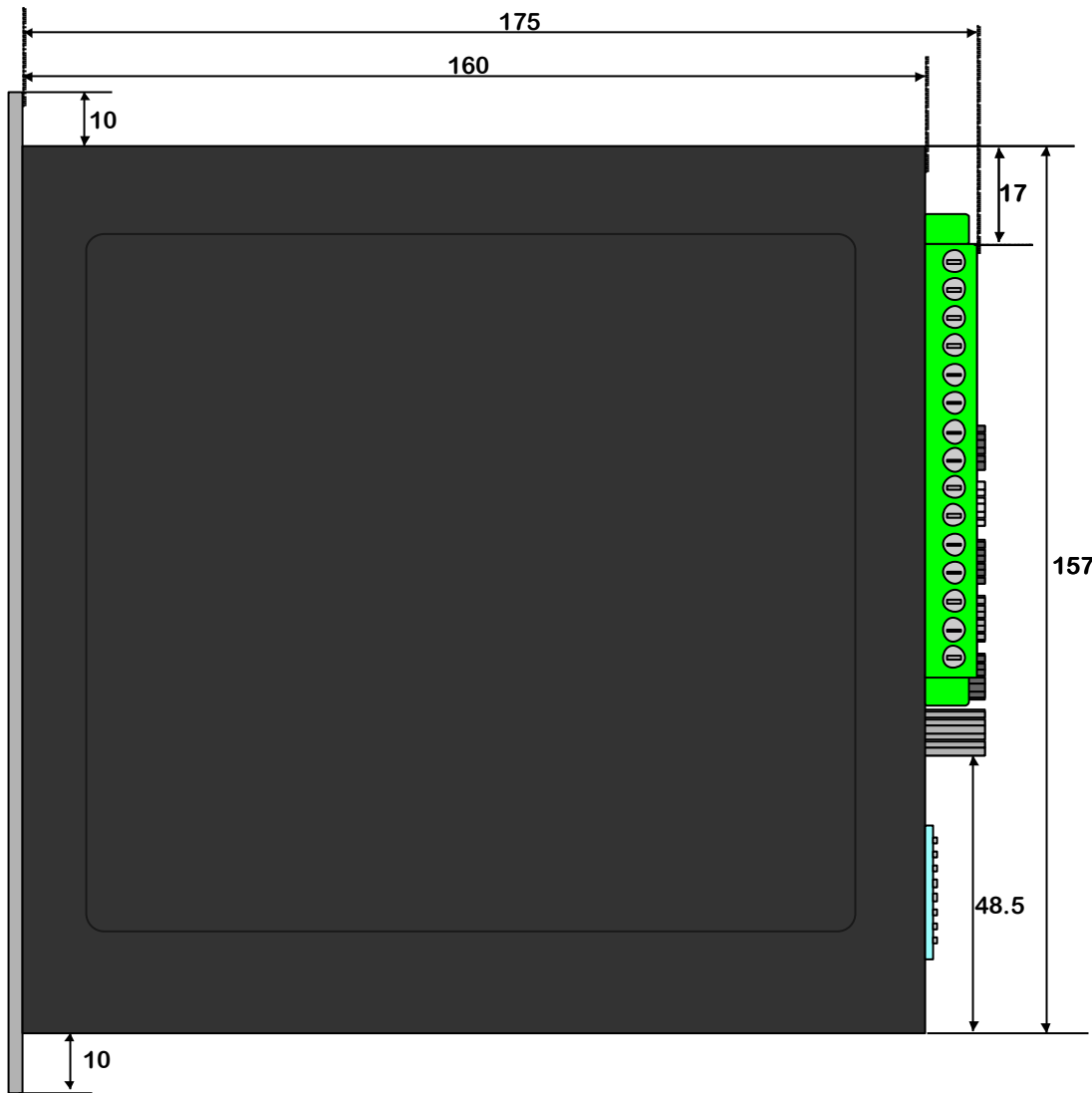

Figure 8-1: Wiring diagram of AQ102 unit.

9 DIMENSIONS AND INSTALLATION

AQ102 is either door mounted or panel mounted in standard 19 inch rack (height of 4U and 1/8 of a unit wide).



AQ102 unit measurements side.cdr

Figure 9-1: AQ102 dimensions in millimetres (side view)

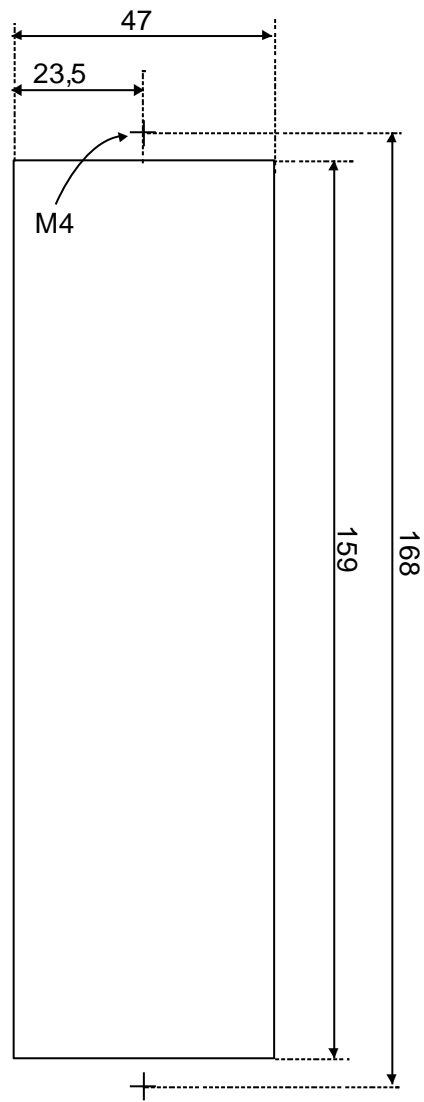

Figure 9-2: AQ102 cut out for panel mounting (millimeters)

10 TESTING

It is recommended that the AQ102 unit is tested prior to substation energizing. Testing is carried out by simulating arc light to each sensor and verifying the tripping and LED indication. For arc light simulation a superior camera flash type is used: Canon Speedlite 430EX or equivalent. For testing of non-latched signals and CBFP function use Mini Maglite 2 CELL AAA or equivalent type of flashlight. Check that camera flash or flashlight has fully charged battery when testing.

10.1 CARRYING OUT TESTING IN LIGHT ONLY MODE

- 1) Check that the dipswitch setting positions are in accordance to your application.
- 2) Activate the camera flash within 20cm (12 inches) of the AQ-06/07/08 fiber loop sensor if in use.
- 3) Verify that the corresponding sensor channel indication LED status is changed to ON.
- 4) Verify the relay output(s) activation(s) by checking the circuit breaker status or by monitoring trip contact status. The circuit breaker should open, or contacts operate. Note: A best practice is to operate the circuit breaker at testing.
- 5) Verify that the corresponding relay output(s) LED(s) indication status is changed to ON
- 6) If binary output (BO1) signal is utilized verify the BO1 signal activation by status change of relevant input where binary output signal is connected or by measuring the signal output voltage. Note that BO1 signal is a non-latched type.
- 7) If binary output signal is utilized verify that BO1 LED is lit.
- 8) Press SET push-button to reset all indications and latches.
- 9) If binary input BI2 is utilized for master trip activate the corresponding binary input and verify that trip has occurred by repeating 4 and 5.
- 10) Press SET push-button to reset all indications and latches.
- 11) Repeat the testing procedure for all sensors.

10.2 CARRYING OUT TESTING IN LIGHT AND CURRENT MODE

- 1) Check that the dipswitch setting positions are in accordance with your application.
- 2) Activate the camera flash within 20cm (12 inches) of the AQ-06/07/08 fiber loop sensor unit and activate the binary input BI1 used for overcurrent condition simultaneously.
- 3) Verify that the sensor channel indication LED status is changed to ON
- 4) Verify that the binary input BI1 indication LED status is changed to ON
- 5) Verify the relay output(s) activation(s) by checking the circuit breaker status or by monitoring trip contact status. Note: A best practice is to operate circuit breaker at testing. The circuit breaker should open or contacts operate.
- 6) Verify that the corresponding relay output(s) LED(s) indication status is changed to ON.
- 7) If binary output BO1 signal is utilized verify the BO1 signal activation by status change of relevant input where binary output signal is connected or by measuring the signal output voltage.
- 8) If binary output signal is utilized verify that BO1 LED is lit. Note that BO1 signal is a non-latched type.
- 9) If other binary input BI2 is in use verify correct operation by activating the input.
- 10) Activate the camera flash within 20cm from the AQ-06/007/08 fiber loop sensor unit and do not activate the binary input BI1 used for overcurrent condition.
- 11) Verify that no trip has occurred and only sensor activation indication LED is ON.
- 12) Verify that BOUT signal is activated (if in use and configured to send light information)
- 13) Press SET push-button to reset all indications and latches.
- 14) If binary input BI2 is utilized for master trip activate the BI2 and verify that trip has occurred by repeating 4 and 5.
- 15) Press SET push-button to reset all indications and latches.
- 16) Repeat the testing procedure for all sensors.

10.3 TESTING THE CBFP FUNCTION

Circuit breaker failure function is tested by leaving light signal and second trip criteria signal (e.g. overcurrent) if applicable active for above set CBFP time of either 100 or 150ms. Trip relay T2 and binary output BO1 shall be active after set time delay.

10.4 TESTING ARC FLASH PROTECTION UNIT OPERATION TIME

The AQ102 operation time test is not required at commissioning as it is performed by the manufacturer as a type test and routine production test. Refer to routine test reports sent with AQ102 unit and consult your nearest Arcteq representative for type test reports.

However, if it is deemed necessary a site timing test may be conducted using below instructions.

- 1) Use a calibrated relay test set
- 2) Connect an output from the relay test set to camera flash type Canon xxx or equivalent input for initializing the flash and configure a relay test set timer to be started simultaneously with flash.
- 3) connect AQ102 trip output T1,T2, T3 or T4 to relay test set input and configure the input to stop the timer
- 4) Place camera flash to maximum 20cm (12 inch) distance of the AQ-06/07/08 fiber loop sensor.
- 5) Initiate flash and timer using relay test set output.
- 6) Read the measured time between simulated arc and trip contact operation.
- 7) Subtract the digital input delay of the relay test set from the final measured time if applicable. For specific test instructions consult the manufacturer of the relay test set.

10.5 TEST PLAN EXAMPLE

Date:	
Substation	
Switchgear:	
AQ102 serial number:	

Preconditions	Light only		Light + current	Remark
Sensor channel 1 setting				
Sensor channel 2 setting				
Sensor channel 3 setting				
Master trip binary input in use (Yes / No):				
Circuit breaker failure protection (CBFP) in use (Yes / No):				
Object activated	LED indication	T1,T2,T3,T4 active	B01 active	
Fiber sensor channel 1				
Fiber sensor channel 2				
Fiber sensor channel 3				
BIN 1				
BIN 2				

Tested by :	
Approved by:	

11 TROUBLESHOOTING GUIDE

Problem	Check	Cross reference
Sensor does not activate when testing	Fiber sensor connection	Chapter 4 of this manual
	Camera (or other test equipment) flash intensity	Chapter 10 of this manual
Trip relay(s) does not operate even if sensor is activated	Dipswitch settings	Chapter 3.4 of this manual

Table 11-1 Troubleshooting guide

12 TECHNICAL DATA

12.1 PROTECTION

Trip time using mechanical trip relays	7ms*
Reset time (arc light stage)	2ms
Protection operational after power up	88ms

*total trip time using arc light (L>) or phase/residual overcurrent (I>) from AQ 110 and arc light (L>)

12.2 AUXILIARY VOLTAGE

Us	80...265Vac/dc (option 18...72Vdc)
Maximum interruption	100ms
Maximum power consumption	5W
Standby current	90mA

12.3 TRIP RELAYS T1, T2, T3, T4

Number	3 NO + 1 NC or 4 NO
Rated voltage	250V ac/dc
Continuous carry	5A
Make and carry for 0.5s	30A
Make and carry for 3s	16A
Breaking capacity DC, when time constant L/R=40ms	40W; 0.36A at 110 Vdc
Contact material	AgNi 90/10

12.4 SYSTEM FAILURE RELAY SF

Number	1
Rated voltage	250V ac/dc
Continuous carry	5A
Make and carry for 0.5s	30A
Make and carry for 3s	16A
Breaking capacity DC, when time constant L/R=40ms	40W; 0.36A at 110 Vdc
Contact material	AgNi 90/10

12.5 BINARY OUTPUT BO1

Rated voltage	+24V dc
Rated current	20mA (max)
Number of outputs	1

12.6 BINARY INPUTS BI1, BI2

Rated voltage	24 or 110 or 220Vdc
Rated current	3 mA
Number of inputs	2

12.7 DISTURBANCE TESTS

EMC test	CE approved and tested according to EN 50081-2, EN 50082-2
Emission - Conducted (EN 55011 class A) - Emitted (EN 55011 class A)	0.15 – 30MHz 30 - 1000Mhz
Immunity - Static discharge (ESD) (According to IEC244-22-2 and EN61000-4-2, severity class 4) - Fast transients (EFT) (According to EN61000-4-4, class III and IEC801-4, level 4) - Surge (According to EN61000-4-5 [09/96], level 4) - RF electromagnetic field test (According. to EN 61000-4-3, class III) - Conducted RF field (According. to EN 61000-4-6, class III)	Air discharge 15kV Contact discharge 8kV Power supply input 4kV, 5/50ns other inputs and outputs 4kV, 5/50ns Between wires 2 kV / 1.2/50µs Between wire and earth 4 kV / 1.2/50µs f=80.....1000MHz 10V/m f=150 kHz.....80Mhz 10V

12.8 VOLTAGE TESTS

Insulation test voltage acc- to IEC 60255-5	2 kV, 50Hz, 1min
Impulse test voltage acc- to IEC 60255-5	5 kV, 1.2/50us, 0.5J

12.9 MECHANICAL TESTS

Vibration test	2 ... 13.2 Hz \pm 3.5mm 13.2 ... 100Hz, \pm 1.0g
Shock/Bump test acc. to IEC 60255-21-2	20g, 1000 bumps/dir.

12.10 CASING AND PACKAGE

Protection degree (front)	IP 50
Protection degree (back)	IP 20
Dimensions (W x H x D mm)	45 x 164 x 157mm
Weight	0.7kg 1.0 kg (with package)

12.11 ENVIRONMENTAL CONDITIONS

Specified ambient service temp. range	-35...+70°C
Transport and storage temp. range	-35...+70°C
Relative humidity	Up to 97%
Altitude	Up to 2000m above the sea level

13 ORDERING CODES

13.1 AQ102 FIBER OPTIC LOOP SENSOR UNIT

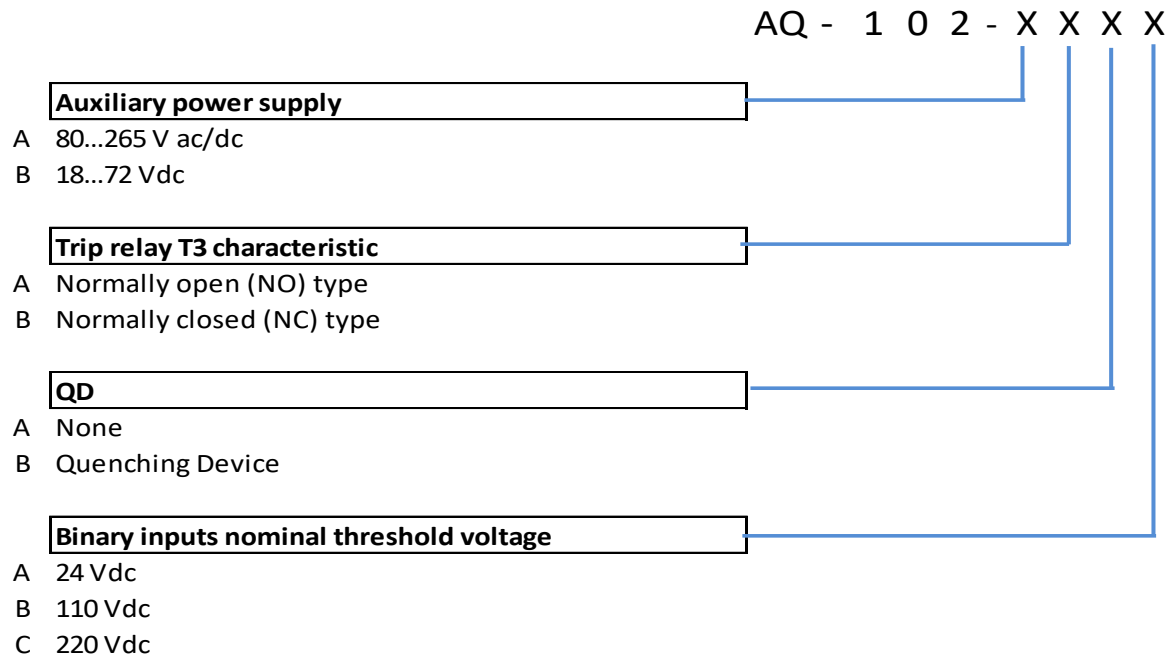

13.2 AQ 0X ARC SENSORS

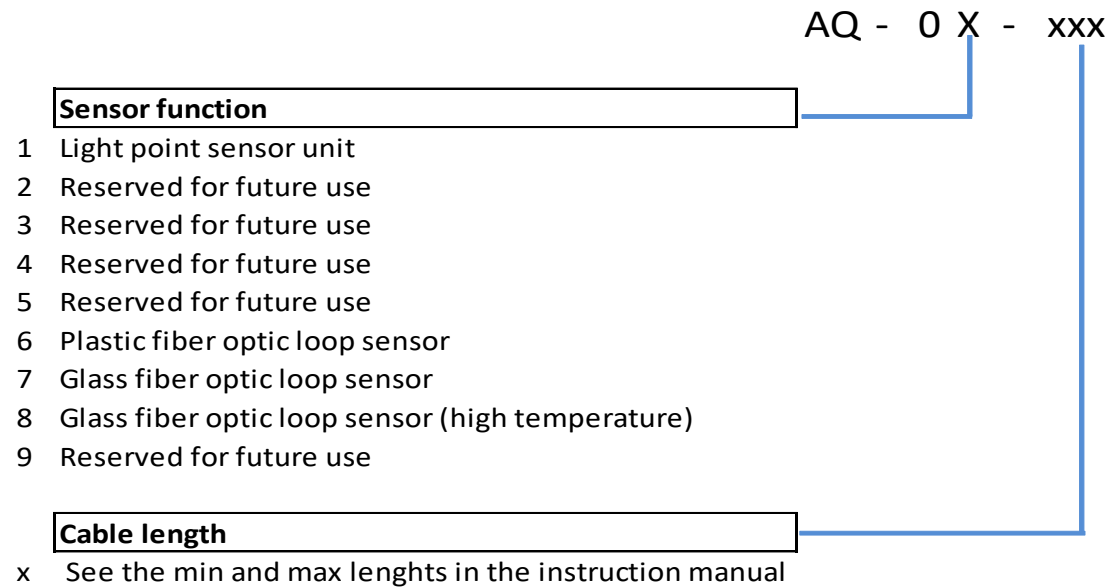

14 REFERENCE INFORMATION

Manufacturer information:

Arcteq Relays Ltd. Finland

Visiting and postal address:

Wolffintie 36 F 12
65200 Vaasa, Finland

Contacts:

Phone: +358 10 3221 370

Fax: +358 10 3221 389

url: www.arcteq.fi

email sales: sales@arcteq.fi

Technical support site: <https://arcteq./support-landing/>

Technical support: +358 10 3221 388 (EET 8:00 – 16:00)